



HydrauPack 45E

Features

- Stackable electric driven hydraulic power unit
- Pressure and load sense control
- Combinable with one or more HP 45E units for higher output flow
- Combinable with an extra tank for higher oil tank volume
- Integrated hydraulic oil circulation cooler
- Flushing connection for separate low pressure flushing

Benefits

24/7

24/7 (de)mobilisation, installation and commissioning



Maintenance during the project



Guaranteed flexibility and high availability



Clear budget and manageable costs

Specifications HP45E

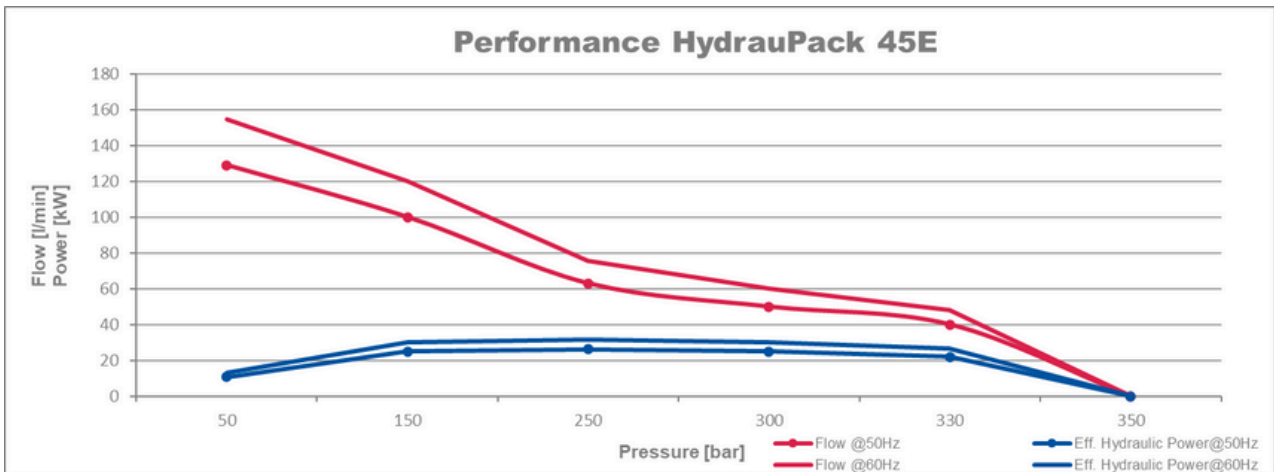
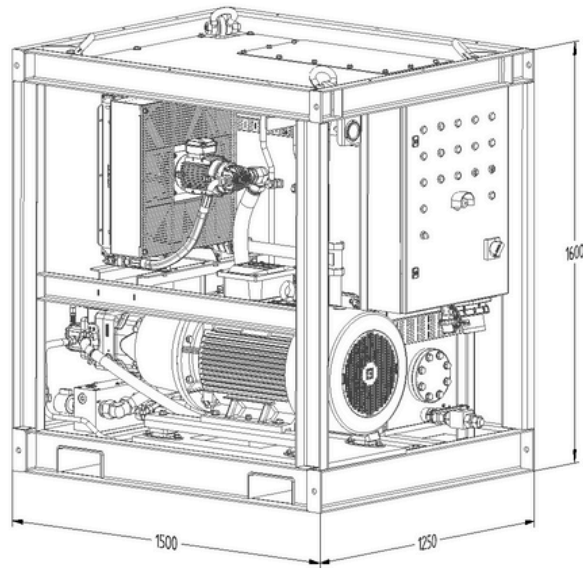

Specifications

Total weight excl./incl. oil	1100 / 1350	kg
Hydraulic oil tank capacity	275	liter
Operational temperature	-15 to +55	°C

Technical specifications

Max. working pressure	350	bar
Max. output flow	130	liter/min @ 50 Hz
	155	liter/min @ 60 Hz
Electric motor power	45	kW @ 400 VAC (50 Hz)
	53	kW @ 440 VAC (60 Hz)
Power supply nominal	400	VAC (50 Hz) - 100A (3P + E)
	440	VAC (60 Hz) - 100A (3P + E)
Pressure (P)		SAE 1-1/4" - 6000 psi
Return (T)		SAE 1-1/2" - 3000 psi
Leak	28 L	
Load sense (LS)	12 S	
Flush (F)	16 S	