

# HydrauPack 45E DNV

## Features

- Stackable electric driven hydraulic power unit
- Combinable with extra tank for higher oil tank volume
- Open hydraulic circuit with pressure and load sense control
- Integrated hydraulic oil circulation cooler
- Lloyd's Register offshore certified acc. DNV rules 2.7-1 and EN 12079 incl. rigging
- Combinable with one or more HP45E units for higher output flow

## Benefits

- 24/7** 24/7 (de)mobilisation, installation and commissioning
- ✓ Guaranteed flexibility and high availability
- ⚙️ Maintenance during the project
- € Clear budget and manageable costs

# Specifications HP45E DNV

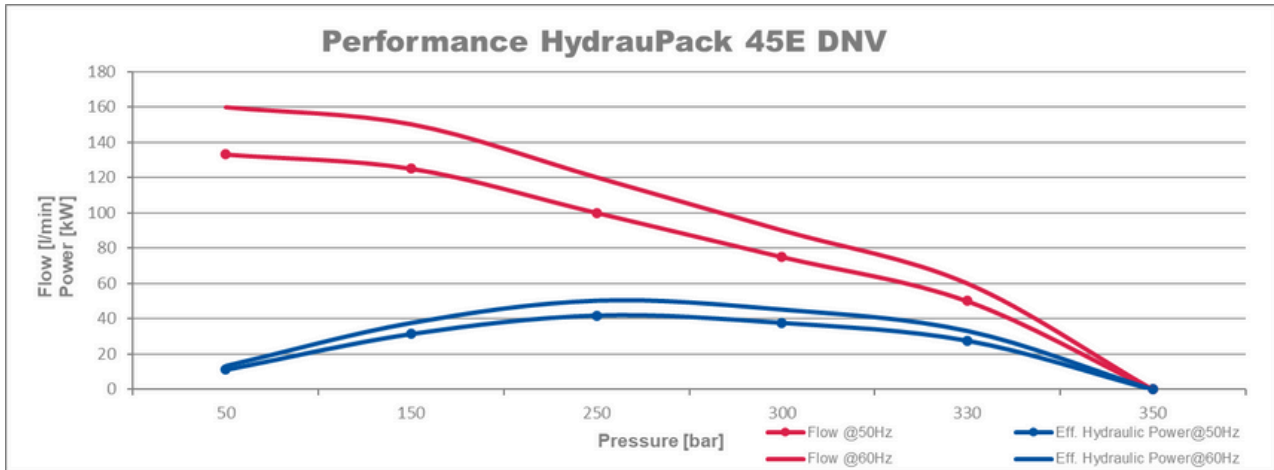
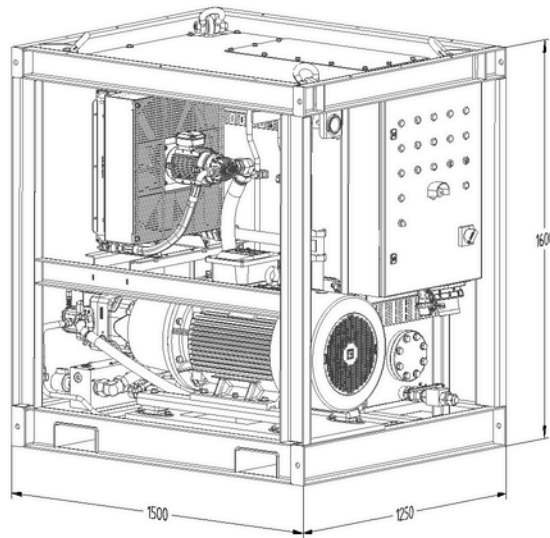

Specifications		
Total weight excl./incl. oil	1400 / 1800	kg
Hydraulic oil tank capacity	450	liter
Operational temperature	-20 to +50	°C
Technical specifications		
Max. working pressure	350	bar
Max. output flow	130	liter/min @ 50 Hz
	155	liter/min @ 60 Hz
Electric motor power	45	kW @ 400 VAC (50 Hz)
	53	kW @ 440 VAC (60 Hz)
Flush capacity	20 - 24	liter/min (50-60 Hz)
Hydraulic fluid	H(V)L P ISO VG 46, 68	
Power supply nominal	400	VAC (50 Hz) - 100A (3P + E)
	440	VAC (60 Hz) - 100A (3P + E)
Pressure (P)	QC 1" Snap-tite 75 N 16-16 RP	
Return (T)	QC 1" Snap-tite 75 C 16-16 RP	
Drain (D)	QC 3/4" Snap-tite 71-3 C 12-12 RP	
Load sense (LS)	QC 1/2" Snap-tite 71-3 C 8-8 RP	
Flush (F)	QC 1/2" Snap-tite 71-3 C 8-8 RP	
Filling point	QC 1/2" flat face acc. ISO 16028 (male)	