



HydrauPack 45E Ex

Features

- Stackable electric driven hydraulic power unit
- Marked with CE Ex II 2G IIB T4 Suitable for use in zone 1
- Offshore-certified rigging acc. DNV 2.7-1 & integrated forklift-trays
- For use in potentially explosive atmospheres (ATEX)
- Certified acc. European Directive 94/9/EC ATEX
- Combinable with other HP45E Ex units and HydrauSupport 1000T

Benefits

- 24/7** 24/7 (de)mobilisation, installation and commissioning
-  Maintenance during the project
-  Guaranteed flexibility and high availability
-  Clear budget and manageable costs

Specifications HP45E Ex

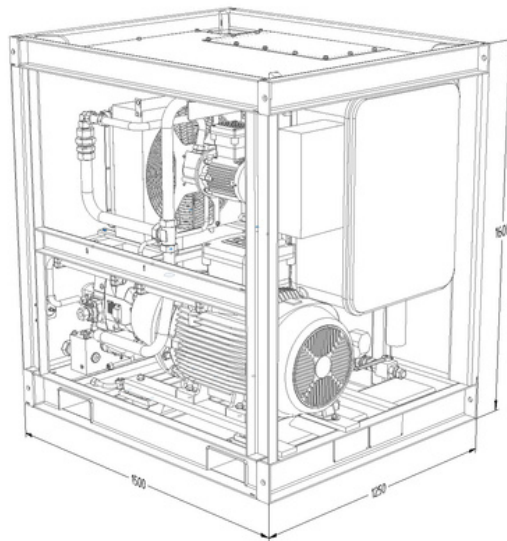

Performance HydraulPack 45E Ex

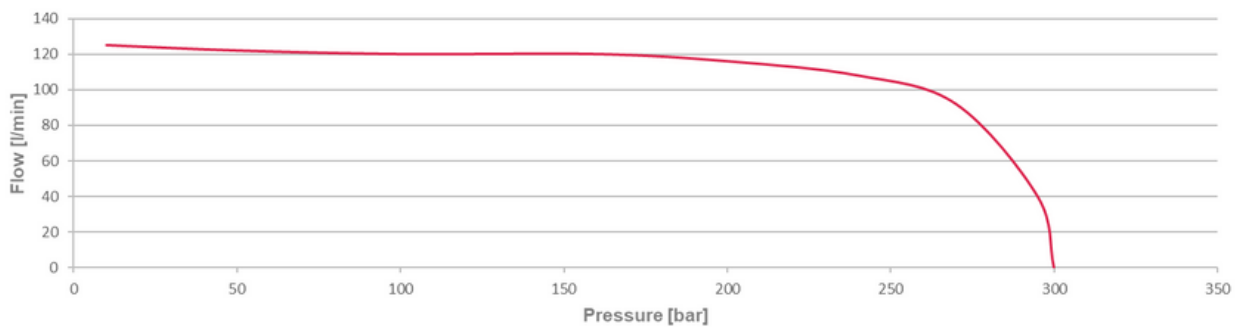

| Specifications | | |
|------------------------------|-------------|-----------------------------|
| Total weight excl./incl. oil | 1900 / 2250 | kg |
| Hydraulic oil tank capacity | 380 | liter |
| Operational temperature | -15 to +50 | °C |
| Technical specifications | | |
| Max. working pressure | 310 | bar |
| Max. output flow | 130 | liter/min @ 50 Hz |
| | 155 | liter/min @ 60 Hz |
| Electric motor power | 45 | kW @ 400 VAC (50 Hz) |
| | 53 | kW @ 440 VAC (60 Hz) |
| Power supply nominal | 400 | VAC (50 Hz) - 125A (3P + E) |
| | 440 | VAC (60 Hz) - 125A (3P + E) |
| Pressure (P) | 30 S | |
| Return (T) | 42 L | |
| Drain (D) | 28 L | |
| Load sense (LS) | 12 S | |
| Flush (F) | 16 S | |