



# HydrauPack 30E

## Features

- Specifically engineered for water-glycol use
- Including emergency stop
- Integrated forklift-trays
- Including power connector on unit: 12A - 6h, 5-pole
- Offshore-certified rigging acc. DNV 2.7-1
- Combinable with one or more other HP30E WG units to obtain higher output flow

## Benefits

- 24/7** 24/7 (de)mobilisation, installation and commissioning
- ✓ Guaranteed flexibility and high availability
- ⚙️ Maintenance during the project
- € Clear budget and manageable costs

## Specifications HP30E

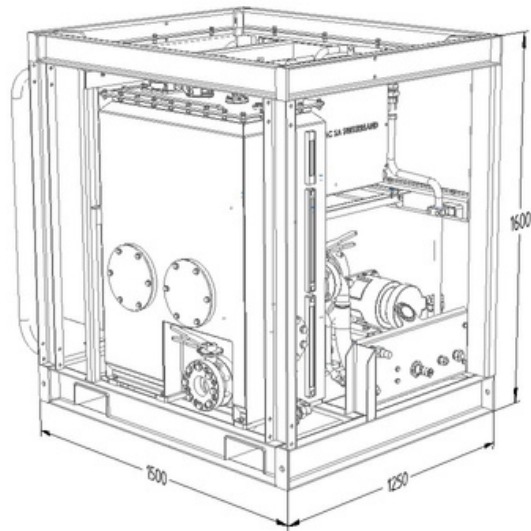

Specifications		
Total weight excl./incl. oil	1250 / 1625	kg
Hydraulic oil tank capacity	400	liter
Operational temperature	-10 to +55	°C
Technical specifications		
Max. working pressure	500	bar
Electric motor power	30	kW frequency drive
Max. output flow	25	liter/min
Revolutions	300 - 1500	rpm
Fixed displacement pump	19	cc/rev.
Power supply nominal	400	VAC (50 Hz) - 100A (3P + N + E)
	440	VAC (60 Hz) - 100A (3P + N + E)
Pressure (P)	16 S	
Retrun (T)	28 L	
Drain (D)	22 L	