



HydrauPack 500

Features

- Diesel driven hydraulic power unit
- Intelligent electronic control system
- Open hydraulic circuit
- Equipped with boost pump
- Lloyd's Register offshore certified acc. to DNV rules 2.7-1 CSC and EN12079 incl. rigging
- Extra temperature controlled cooling and filtration systems.

Benefits

- 24/7** 24/7 (de)mobilisation, installation and commissioning
- ✓ Guaranteed flexibility and high availability
- ⚙️ Maintenance during the project
- € Clear budget and manageable costs

Specifications HP500

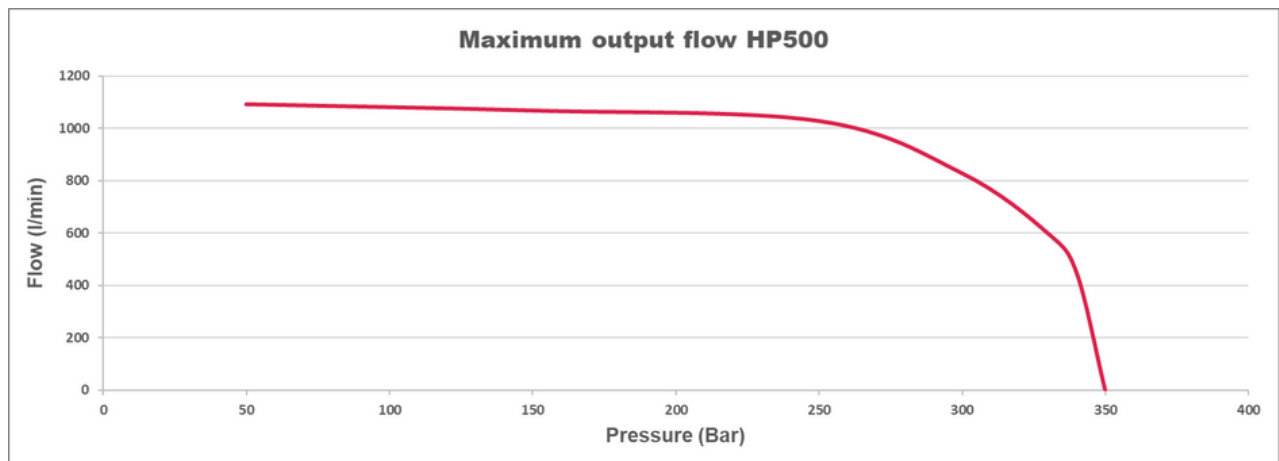
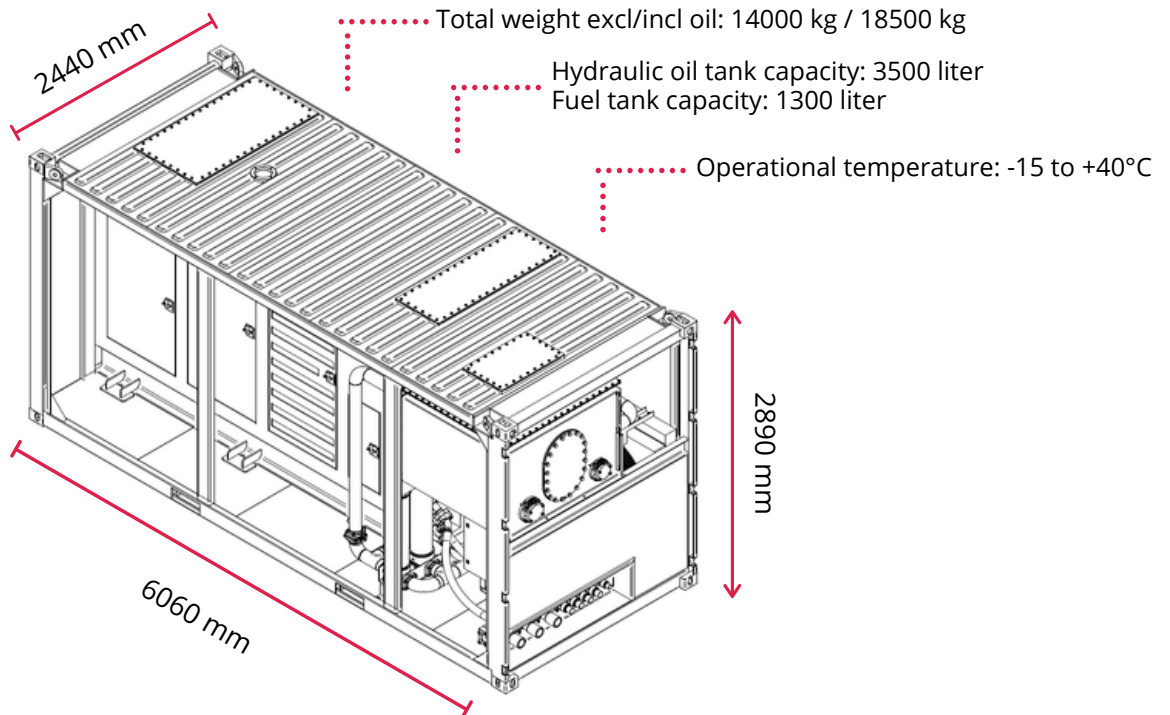

Max. working pressure	350 bar
Max. output flow	950 liter/min
Max. output flow @ 350 bar	680 liter/min
Total engine power	494 kW (25°C)
Effective hydraulic power	Approx. 410 kW (25°C)
Boost pump	195 liter/min @ 25 bar
Hydraulic fluid	H(V)LP ISO VG 46
Pressure (P)	3 pcs Q.C. Snap-tite series 75, 2" (male)
Return oil (T)	4 pcs. Q.C. Tema T20020, 2" (male)
Drain (L)	Q.C. Tema T15020 , 1 1/2" (male)
Auxiliary (A + B)	1/2" BSP, 16S, 4 pcs
Boost pressure (PB)	2" SAE 3000 psi
Flush (F)	1" BSP, 28L
Filling point	Q.C. flat face acc. ISO 16028, 1/2" (male)
Power supply nominal	400/440 VAC, 32 A, 50/60 Hz, 3 phase +E